

# DS1

# SERIES

PAGE 25  
DOUBLE  
SHAFT CLAMPS

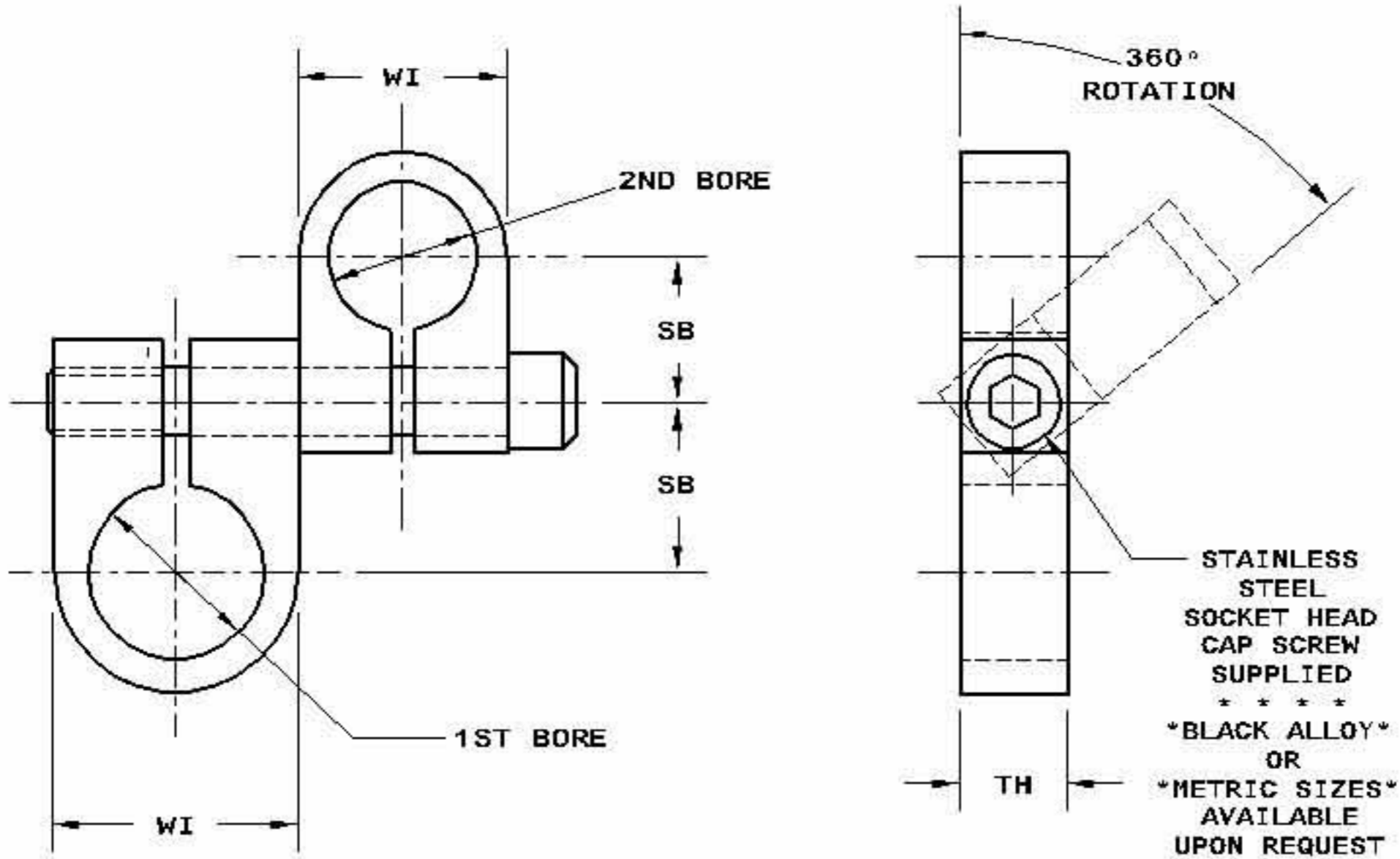

SUFFIX	MATERIAL	FINISH
S	STAINLESS STEEL 303	CLEAR PASSIVATE
H	STAINLESS STEEL 416	RC 38-45 PASSIVATE

TOLERANCES			
INCH		METRIC	
.XX	±.016	.X	±.4
.XXX	±.005	.XX	±.13
BORE	+.001	BORE	+.026

PART No. BREAKDOWN				
SERIES		1ST BORE	2ND BORE	MAT
DS1	-	188	- - - *	H

\*SECOND BORE SIZE MUST BE CHOSEN BY CUSTOMER  
EXAMPLE: DS1-188-.251H FOR .188 FIRST BORE,  
.251 SECOND BORE AND H, FOR STAINLESS STEEL  
416 AS THE MATERIAL.

CATALOG NO.	SUFFIX	1ST BORE		WI		TH		SB		SCREW
		IN	MM	IN	MM	IN	MM	IN	MM	IN & MM*
DS1-188- - - -	S H	.188	4.78							
DS1-197- - - -	S H	.197	5.00	.312	7.92	.250	6.35	.19	4.8	6-32
DS1-236- - - -	S H	.236	6.00							
DS1-251- - - -	S H	.251	6.38	.375	9.53	.250	6.35	.25	6.4	6-32
DS1-276- - - -	S H	.276	7.00							
DS1-313- - - -	S H	.313	7.95							
DS1-315- - - -	S H	.315	8.00	.437	11.10	.250	6.35	.25	6.4	6-32
DS1-354- - - -	S H	.354	9.00							
DS1-376- - - -	S H	.376	9.55	.500	12.70	.250	6.35	.28	7.1	6-32
DS1-394- - - -	S H	.394	10.00							
DS1-438- - - -	S H	.438	11.13							
DS1-472- - - -	S H	.472	12.00	.625	15.88	.250	6.35	.34	8.6	6-32
DS1-501- - - -	S H	.501	12.73							
DS1-512- - - -	S	.512	13.00							

## IMPULSE MECHANISMS INC

78-82 N INDUSTRY CT  
DEER PARK NY 11729  
TEL (631) 586-5755  
FAX (631) 586-5757