

SH9

SERIES

PAGE 44
SHAFT
HUB CLAMPS

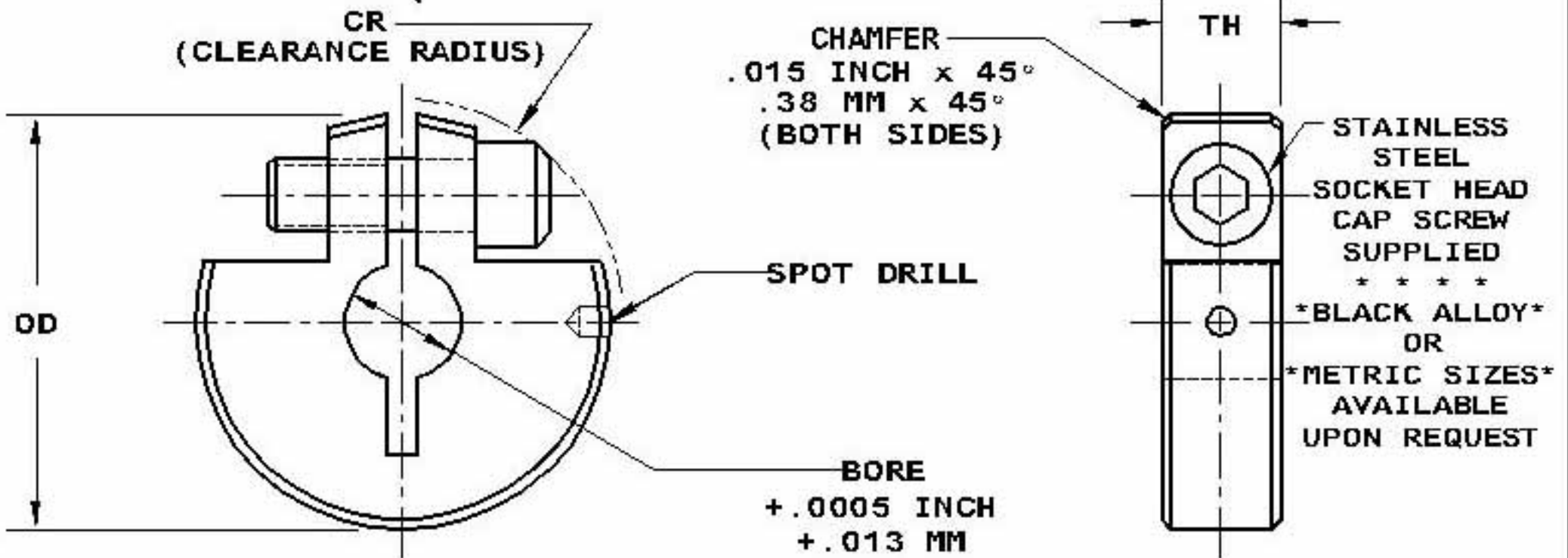

SUFFIX	MATERIAL	FINISH
S	STAINLESS STEEL 303	CLEAR PASSIVATE
F	STAINLESS STEEL 416	HARDENED

TOLERANCES			
INCH		METRIC	
.XX	±.016	.X	±.4

CATALOG NO.	SUFFIX		BORE		OD		TH		CR		SPOT		SCREW
			INCH	MM	INCH	MM	INCH	MM	INCH	MM	INCH	MM	INCH&MM*
SH9-1616.1181		F	.1181	3.000									
SH9-1616.1250		F	.1250	3.175									
SH9-1616.1417		F	.1417	3.600									
SH9-1616.1562		F	.1562	3.967	.500	12.70	.160	4.06	.30	7.6	.06	1.6	2-56
SH9-1616.1574		F	.1574	4.000									
SH9-1616.1811		F	.1811	4.600									
SH9-1616.1875	S	F	.1875	4.763									
SH9-1916.2500		F	.2500	6.350									
SH9-1916.2598		F	.2598	6.600	.594	15.09	.160	4.06	.34	8.6	.06	1.6	2-56
SH9-1916.2756		F	.2756	7.000									

IMPULSE

MECHANISMS INC

78-82 N INDUSTRY CT
DEER PARK NY 11729
TEL (631) 586-5755
FAX (631) 586-5757